

The silent revolution

Responding to strong demand for electrification in the small vehicle categories, Semikron's latest inverter platform is designed to meet challenging and variable requirements for low-voltage applications

▶▶ Since the launch of Toyota's first Prius in 1997, the public has thought about electromobility in terms of the automobile mega market. But even though that may be the most important market, it is not the first in its evolution. The material-handling industry started to build its future on electrified vehicles much earlier. In 2018, more than one million electrified vehicles entered service in that sector globally – almost exclusively operating from low battery voltages between 24V and 96V.

The material-handling industry serves as an example of demand-driven electrification. Besides the smaller pallet movers, where warehouse use led to widespread demand for electrification from as early as the 1950s, the larger counterbalanced forklifts and tow trucks started their tour against their gas- or diesel-powered counterparts in the late 1980s.

The uptake differs greatly across regions. Taking the large truck category as an example, the number of electric models sold in Europe surpassed combustion-engine models in 2015, but globally the percentage of electrification is just touching a third today.

Material-handling vehicles are not the only success story. Starting from bicycles, through e-rickshaws, tuk-tuks and golf carts all the way to small passenger cars, the silent low-voltage revolution is on the move.

The latest category of vehicles that are coming into the focus of electrification are small tractors and diggers. Low-voltage powered vehicles are often exempt from subsidies but still the number of these vehicles is constantly rising. The simple reasons are that they are cheap, safe and silent, the electricity and maintenance costs

are very low, and they do not pollute.

Semikron, a leading supplier of power electronics equipment, has been providing products for vehicle electrification for more than 25 years. Starting with material-handling applications – such as forklifts – in the early 1990s, Semikron has since equipped more than 1.5 million vehicles for material handling. It has also provided power

electronic products for more than 200,000 passenger cars, and more than 50,000 traction inverters for electrified buses in China.

The company's equipment has accumulated in excess of several billion field operating hours overall. Semikron says the resulting field data underlines the fundamental advantages of solder-free assemblies when it comes to power

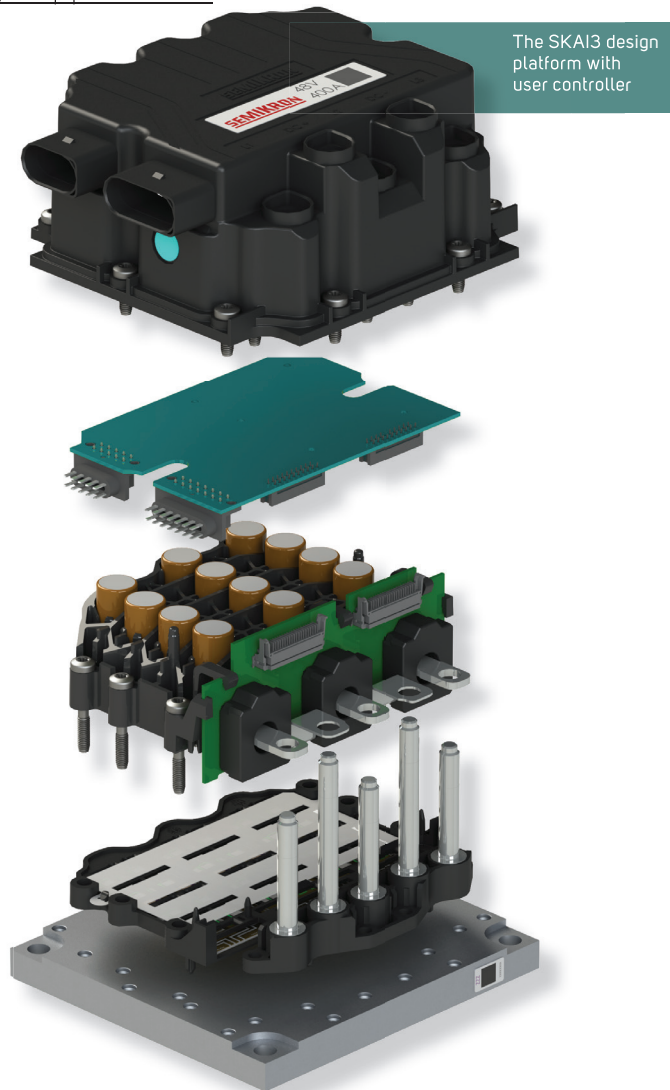

semiconductors. Solder-free assemblies are standard in all Semikron's SKAI inverters. The company explains that a lack of solder joints enables a power semiconductor to fulfil challenging requirements for load power cycling, which is necessary given the frequent accelerations, decelerations and lifting actions involved in forklift operation.

The growing number of low-voltage applications necessitates a wide range of solutions to match requirements for performance, size and function. The upcoming SKAI3 LV, the third generation of Semikron's MOSFET-based inverter, offers a power electronic platform that can easily be equipped by the drivetrain designer with the controller and software combination needed to meet application requirements. A power density of more than 25kVA/liter and a total volume of less than 1.8 liters allows even the standard design to fit into many applications. The product can also be used as a starting point for a one-off design where the customer has specific requirements regarding space, cooling or power connectors.

Semikron is contributing to the global decarbonization effort by offering a wide range of products for or electrified vehicles. For all low-voltage applications, Semikron offers the SKAI3 LV inverter platform to make it easy for vehicle manufacturers, drivetrain suppliers and inverter specialists to develop the optimum design. ©

FREE READER INQUIRY SERVICE
To learn more about Semikron,
visit: www.magupdate.co.uk/PEHV